

KS-1330

> 32" Kitchen Display System



Features



- Fanless system with Intel® Atom™ processor E3827 1.75 GHz
- Fast data input via P-CAP touchscreen
- Full system IP55 waterproof design
- Rear I/O waterproof design
- M12 type I/O connectors for harsh environments
- Full-HD display
- Support 10 points touch function
- Support wall mount

Applications

- Restaurant
- Product information
- Commercial advertisement
- Food & drink service

Highlights

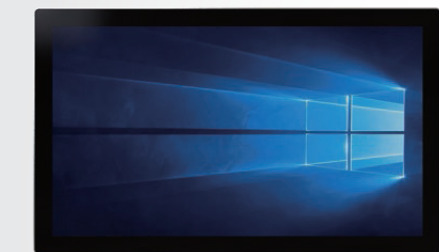

Power Button

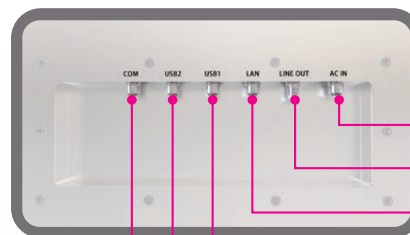

COM (Optional)

USB 2.0 (Optional)

USB 2.0 (Optional)

100V/240V AC Input

Line Out (Optional)

LAN

*All information contained in this document is subject to change without prior notice.

Specifications



System	CPU Support	Intel® Atom™ E3827 SoC (2C 1M 1.75 GHz 8W, wide-range temperature)
	Memory	1 x 4G DDR3L SO-DIMM slot (up to 8GB)
	Network	Gigabit 10/100/1000 Base-T Fast Ethernet
	Power Supply	164 watt power adapter
	Audio	2W speaker
	System Weight	With power adapter approx. 28 kg
	Dimensions (W x H x D)	774 x 469 x 84 mm
	O.S. Support	Windows 10 / Windows 7 / POSReady 7
Storage	SATA	1 x 2.5" HDD or SSD
I/O Ports	USB	2 x USB (M12 waterproof connector)
	Serial Port	1 x DB9 (M12 waterproof connector)
	LAN	1 x RJ45 (M12 waterproof connector)
	Line Out	1 x Audio Out (M12 waterproof connector)
	DC In	1 x AC In power (M12 waterproof connector)
	Operating Display	LCD
Max. Resolution		1920 x 1080
Brightness		500 cd/m ²
Touchscreen		P-CAP
Environment	EMC & Safety	CE / FCC
	Operating Temp.	0°C~40°C
	Storage Temp.	-20°C~60°C
	Humidity	20%~90%

Dimensions

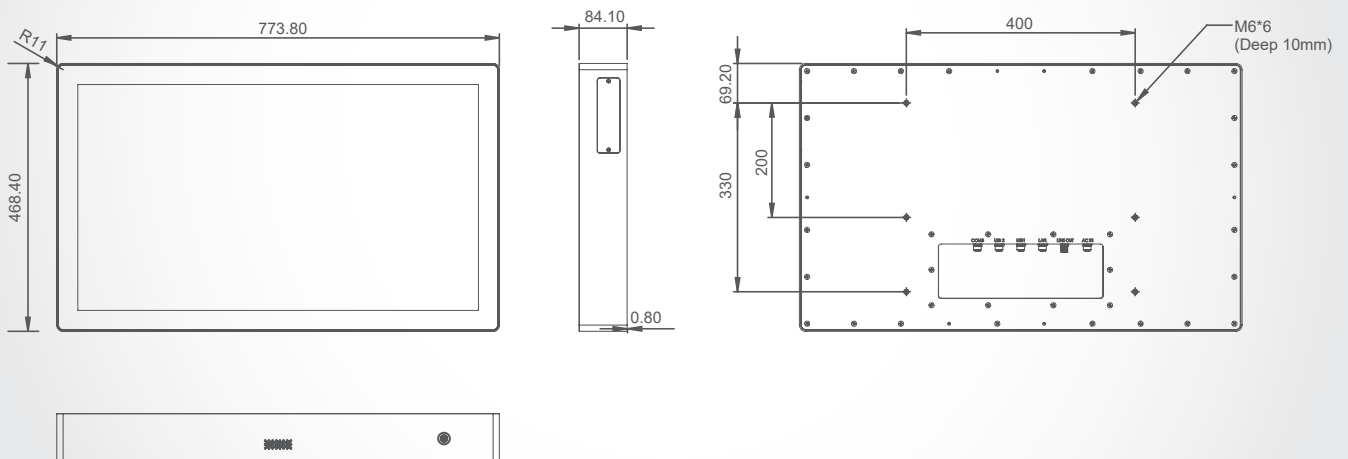

unit: mm